

Model Number Designation

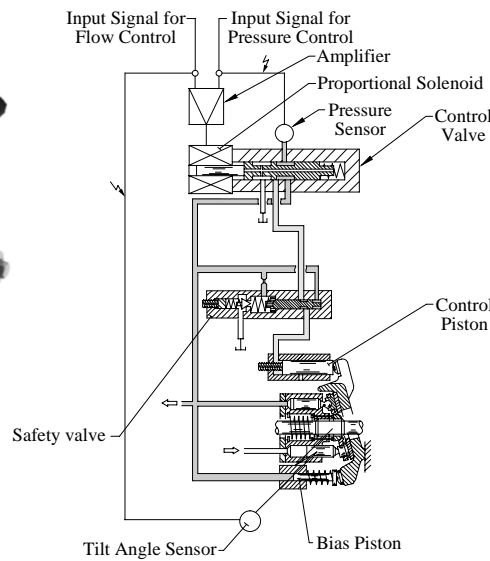

Performance Characteristics

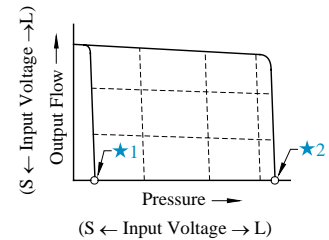

- ★1. Unloading pressure when input signal is 0 V.
- ★2. Safety valve setting pressure

Graphic Symbols

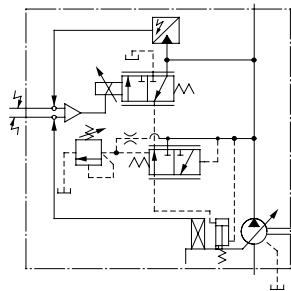

A16/A22/A37/A56

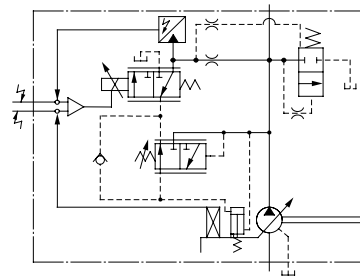

A70/A90/A145

Model Number Designation

A70	-F	R	04E	16	M	A	-60	-60	*
Series Number	Mounting	Direction of Rotation	Control Type	Control Pressure at Input Signal is 5 V	Unit of Control Pressure	Type of Outboard Pump	Compensation Number	Design Number	Design Std.
A16 (15.8 cm ³ /rev)	F: Flange Mtg.	(Viewed from Shaft End)	04E: Proportional Pressure & Flow Control Type	Use the same measure of the control pressure as shown on the right, 6.9 MPa (70 kgf/cm ² , 1000 PSI) specify within the range of maximum operating pressure	None: kgf/cm ² M: MPa P: PSI	—	06	42	Refer to ★4
A22 (22.2 cm ³ /rev)							11	42	
A37 (36.9 cm ³ /rev)							01	42	
A56 (56.2 cm ³ /rev)							02	42	
A70 (70.0 cm ³ /rev)	L: Foot Mtg.	R: Clockwise (Normal)	★1			Outboard pump models A: A16,A22 PV2R1 B: A37 PV2R2	60	60	
A90 (91.0 cm ³ /rev)							60	60	
A145 (145.0 cm ³ /rev)							60	60	

- ★1. Available to supply pump with anti-clockwise rotation. Consult Yuken for details.
- ★2. Models A70/A90/A145 can be used as double pumps. Chose either A or B suitable for the outboard pump. For the mounting of outboard pumps, make inquires separately. If you use these models as single pumps, generally specify "A".
- ★3. Amplifier Compensation Number may differ according to the main machine conditions. Consult Yuken for detail
- ★4. Design Standards: None Japanese Standard "JIS"
80 European Design Standard
90 N. American Design Standard

Specifications

Descriptions		Model Numbers	A16	A22	A37	A56	A70	A90	A145
Geometric Displacement	cm ³ /rev (cu. in./rev)		15.8 (.964)	22.2 (1.355)	36.9 (2.25)	56.2 (3.43)	70.0 (4.27)	91.0 (5.55)	145.0 (8.85)
Operating Pres. MPa (PSI)	Rated ^{*2}		16 (2320)	16 (2320)	16 (2320)	16 (2320)	25 (3630)	25 (3630)	25 (3630)
	Intermittent ^{*1}		21 (3050)	16 (2320)	21 (3050)	21 (3050)	28 (4060)	28 (4060)	28 (4060)
Shaft Speed Range	r/min		600 - 1800						
Flow Control	Max. Flow ^{*3}	L/min (U.S. GPM)	28.4 (7.5)	40.0 (10.6)	66.4 (17.5)	101.0 (26.7)	126.0 (33.3)	163.0 (43.1)	261.0 (69.0)
	Min. Pres. Required for Flow Adj.	MPa (PSI)	2.0 (290) ^{*4}						
	Hysteresis		Less than 1 %						
	Repeatability		Less than 1 %						
	Input Signal		Max. Flow / 5 V DC						
Pressure Control	Min. Adjustment Pressure	MPa (PSI)	0.7 (100)						
	Hysteresis		Less than 1 %						
	Repeatability		Less than 1 %						
	Input Signal		Specified Control Pressure / 5 V DC						
Coil Resistance	Ω [@ 20°C (68 °F)]	10							
Input Impedance		Flow Control : 10kΩ Pres. Control : 10kΩ							
Supply Electric Power		24 V DC (21 - 28 V Included Ripple)							
Power Input (Max.)	W	30							
Output Signal	Flow		5 V DC/Max. Flow						
	Pressure		5 V DC/Specified Control Pressure						
Alarm Signal Output (Open Collector)		Voltage : Max. 30 V DC Current : Max. 40 mA							
Ambient Temperature	°C (°F)	0 - 50 (32 - 122) (With Circulated Air)							
Approx. Mass kg (lbs.)	Flange Mtg.		20.5 (45.2)	20.5 (45.2)	32.0 (70.6)	39.0 (86.0)	64.0 (141)	76.5 (169)	96.4 (213)
	Foot Mtg.		22.7 (50.1)	22.7 (50.1)	36.3 (80.0)	43.3 (95.5)	76.0 (168)	97.0 (214)	121.4 (268)

- ★1. Whenever setting pressure, make sure the full cut-off pressure never exceeds the maximum intermittent pressure.
- ★2. When operating the pump exceeding the rated pressure, operating conditions are restricted.
Refer to page 6 for the details.
- ★3. Maximum flow differs to shaft speed.
The value listed above indicates shaft speed of 1800 r/min.
For other shaft speed calculate by the ratio of shaft speed.
- ★4. To secure the required minimum pressure, special sequence valves are available, to be directly installed at the discharge port of the pump. Consult Yuken for details.

Pipe Flange Kits

For Pipe flange, refer to form of pressure compensator type on page 7.

Instructions

Input Signal

The pump is on unload condition when the pump is operated without input signal voltage.

Electric Source

Always turn off electric source whenever the connector for swash plate tilt angle sensor is removed.

Compensation of Pump Maximum Regulated Flow at Frequency

If the same maximum flow is required at 50 Hz or 60 Hz, connect short plug in the amplifier to 60 Hz at the place where supplied frequency is 60 Hz. At this condition, maximum flow comes to the same value at 50 Hz.

If short plug is used at 60 Hz without making the change, maximum flow increased in proportion to frequency.

Painting on Amp. Box and Solenoid

To maintain suitable radiation effect, the amp. Box and the solenoid of the control valve should not be painted.

Typical Pump Characteristics

Output Flow vs. Input Signal

● A16

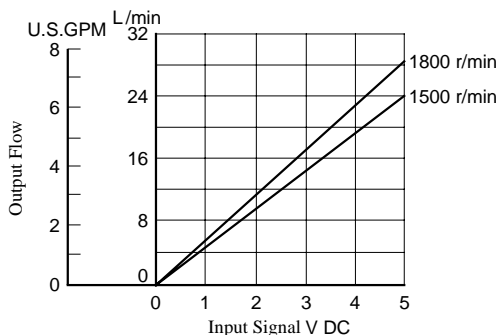

● A56

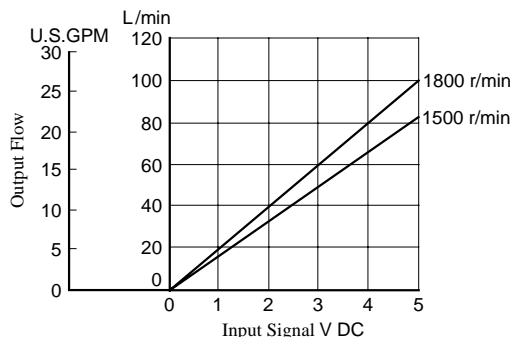

● A22

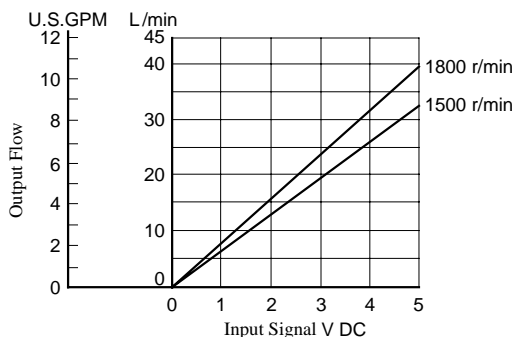

● A70

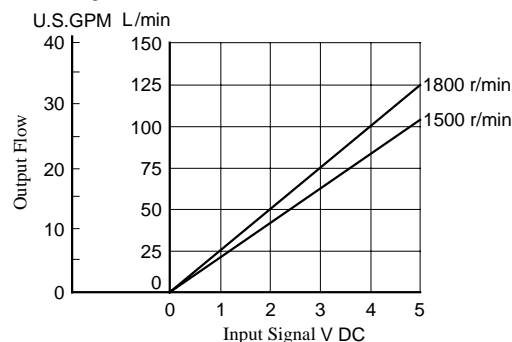

● A37

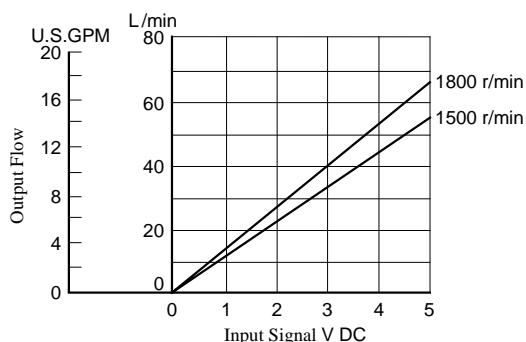

● A90

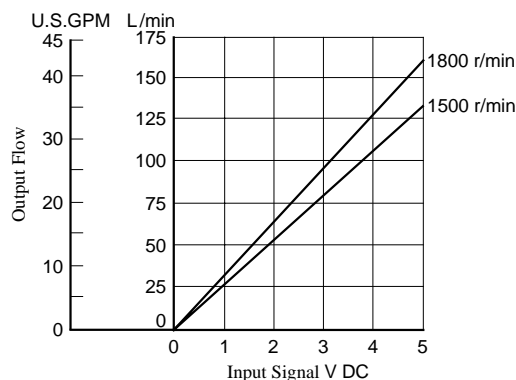

Note: Pump characteristics at 1800 r/min is the same as those at 1500 r/min where frequency is compensated. (Refer to page 48.)

● A145

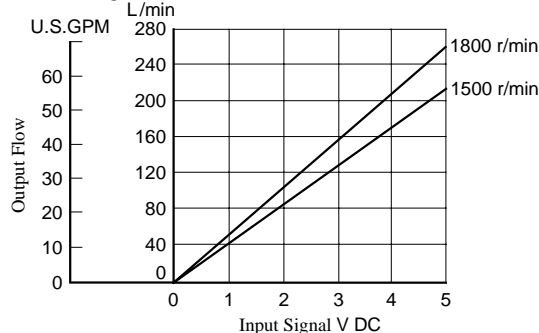

Full Cut-off Pres. vs. Input Signal

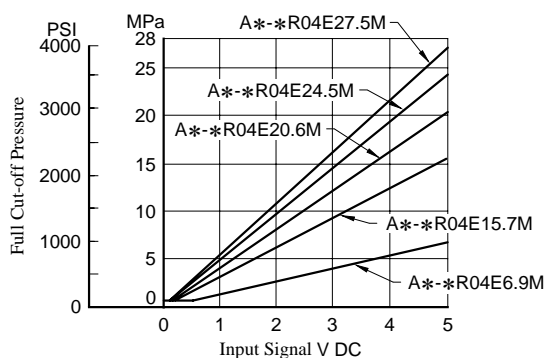

Refer to page 10 to 16 for performance characteristics of pressure compensator type excluding characteristics appeared on this catalogue.

Flange Mtg. : A16-FR04E*-06-42/4280/4290
A22-FR04E*-11-42/4280/4290

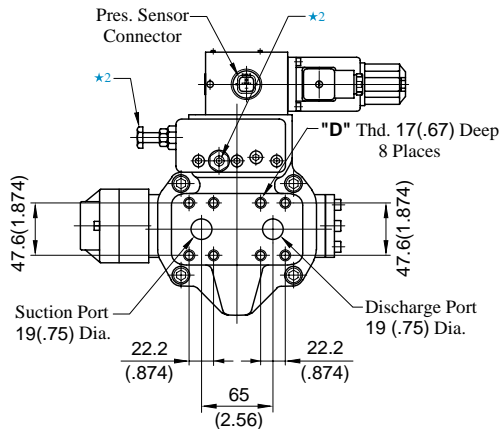
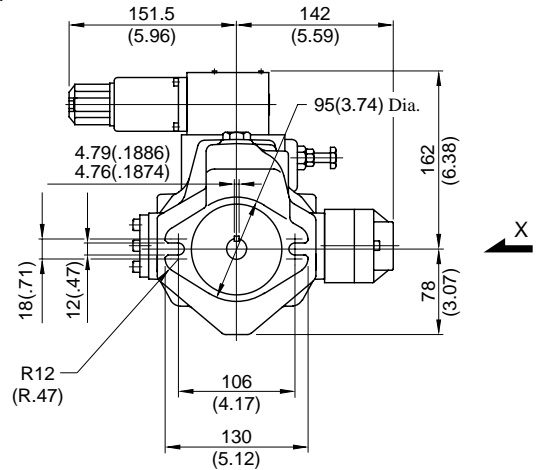
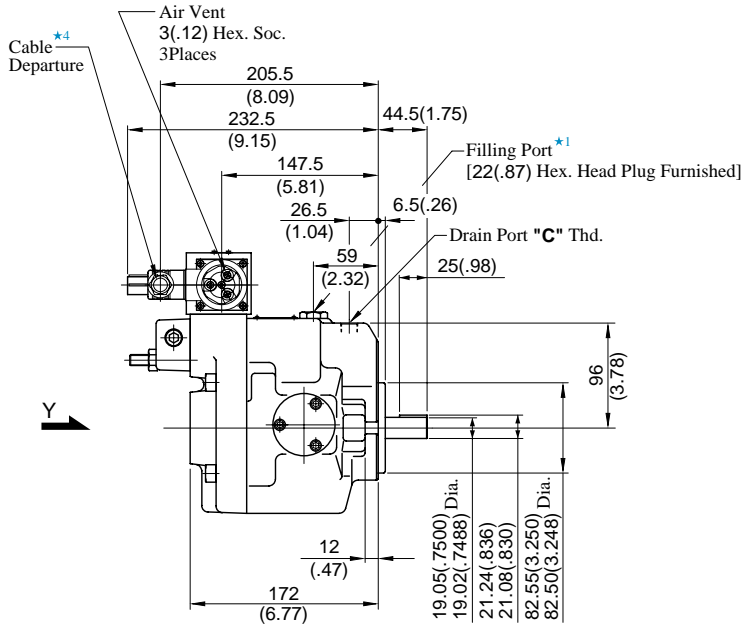

View Arrow Y

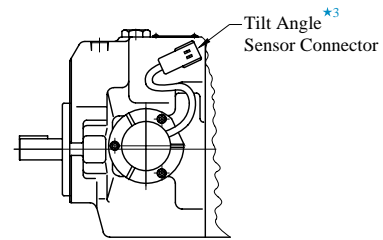

View Arrow X

- ★ 1. Install the pump so that the "Filling Port" is at the top.
- ★ 2. Do not touch the screw because it is adjusted at the time of shipment.
- ★ 3. For cable connection with amplifiers, see page 56.
- ★ 4. Cable Applicable:
Outside Dia. 8-10mm (.31-.39 IN.)
Conductor AreaNot Exceeding 1.5mm² (.002 Sq. IN.)

Model Numbers	"C" Thd.	"D" Thd.
A16/A22-FR04E*-*-42	Rc 3/8	M10
A16/A22-FR04E*-*-4280	3/8 BSP.F	
A16/A22-FR04E*-*-4290	3/8 NPT	3/8-16 UNC

DIMENSIONS IN
MILLIMETRES (INCHES)

● Foot Mounting Type

Mounting bracket is common to that of pressure compensator model.
Refer to page 18 for the dimensions of mounting bracket.

Installation Drawing

Flange Mtg. : A37-FR04E*-01-42/4280/4290

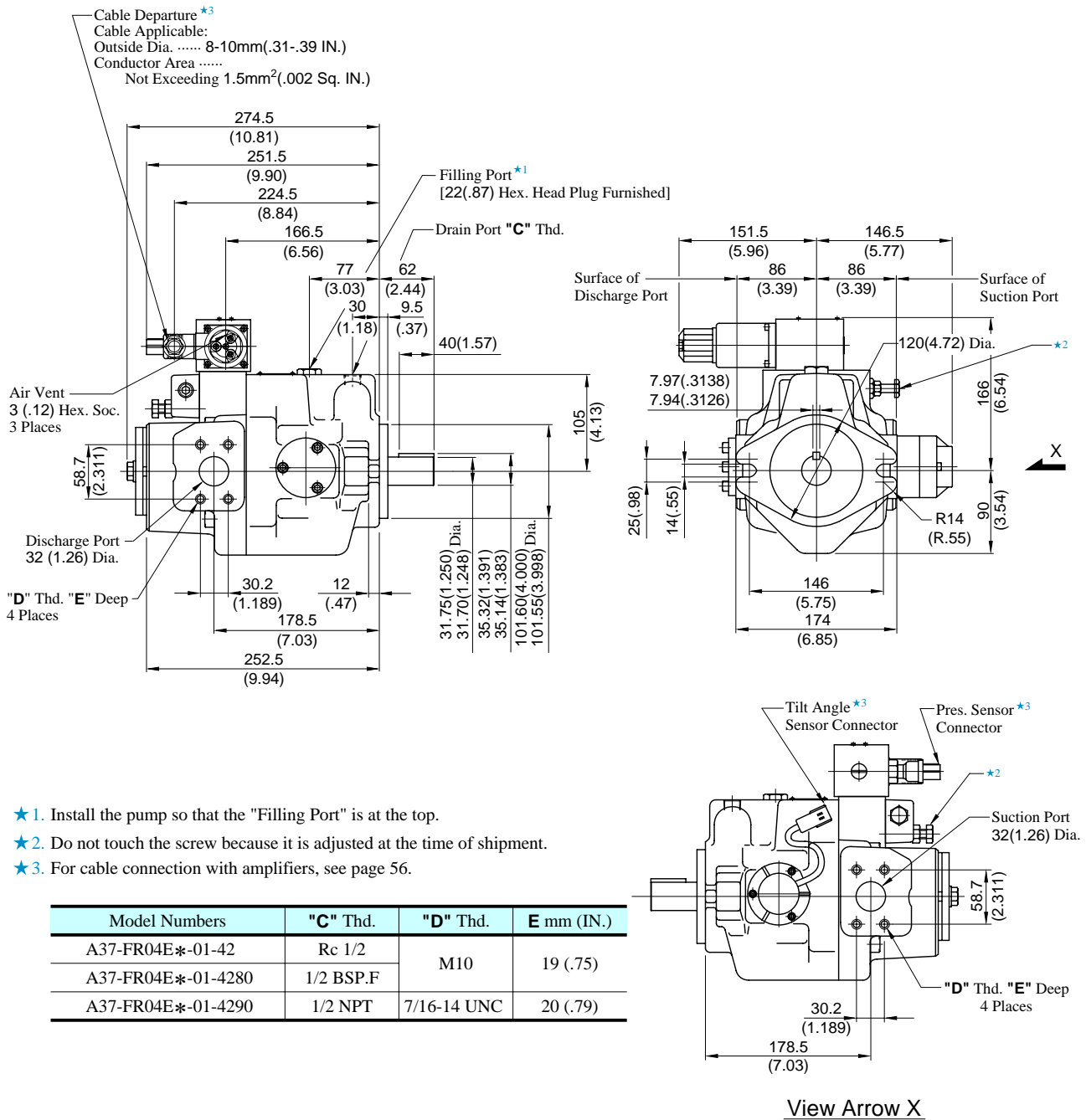

DIMENSIONS IN
MILLIMETRES (INCHES)

● Foot Mounting Type

Mounting bracket is common to that of pressure compensator model.
Refer to page 19 for the dimensions of mounting bracket.

Flange Mtg. : A56-FR04E*-02-42/4280/4290

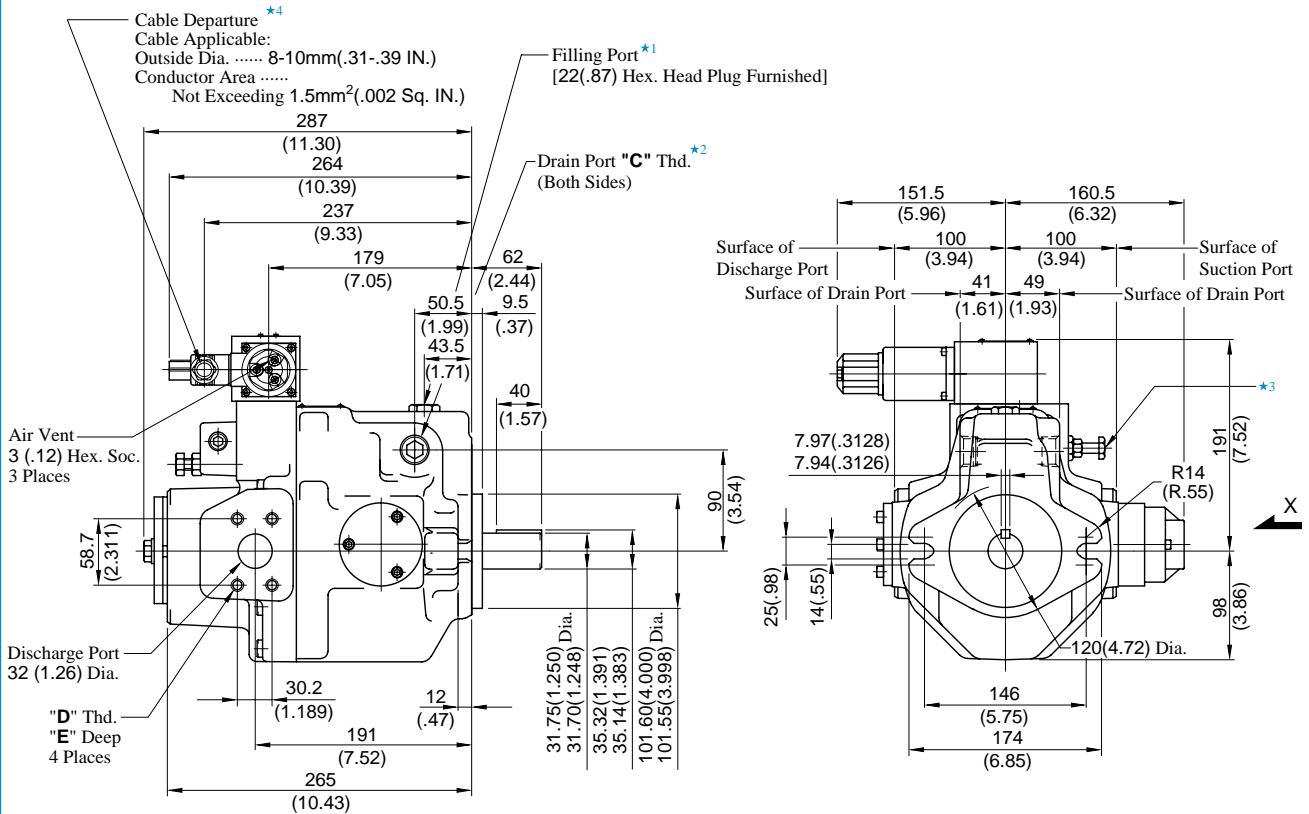

- ★1. Install the pump so that the "Filling Port" is at the top.
- ★2. Use either port of two drain ports at your option. Keep the remaining port plugged. Note that on the European design standard (4280 Design), only the left side, as viewed from the shaft end, of the drain port is machined.
- ★3. Do not touch the screw because it is adjusted at the time of shipment.
- ★4. For cable connection with amplifiers, see page 56.

Model Numbers	"C" Thd.	"D" Thd.	E mm (IN.)
A56-FR04E*-02-42	Rc 3/4	M10	19 (.75)
A56-FR04E*-02-4280	3/4 BSP.F		
A56-FR04E*-02-4290	3/4 NPT	7/16-14 UNC	20 (.79)

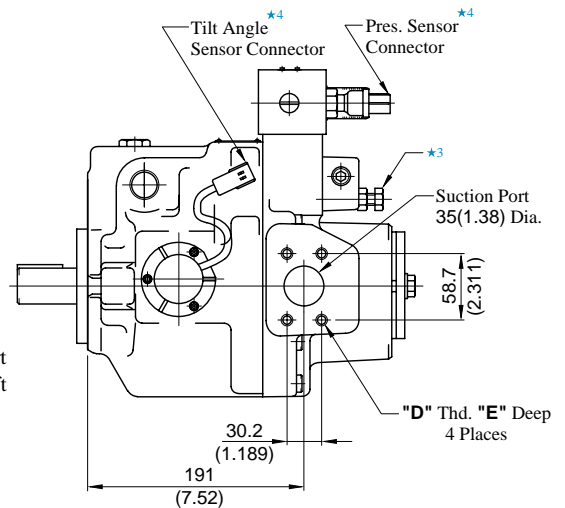

DIMENSIONS IN
MILLIMETRES (INCHES)

● Foot Mounting Type

Mounting bracket is common to that of pressure compensator model.
Refer to page 20 for the dimensions of mounting bracket.

Installation Drawing

Flange Mtg. : A70-FR04E**-60-60/6080/6090

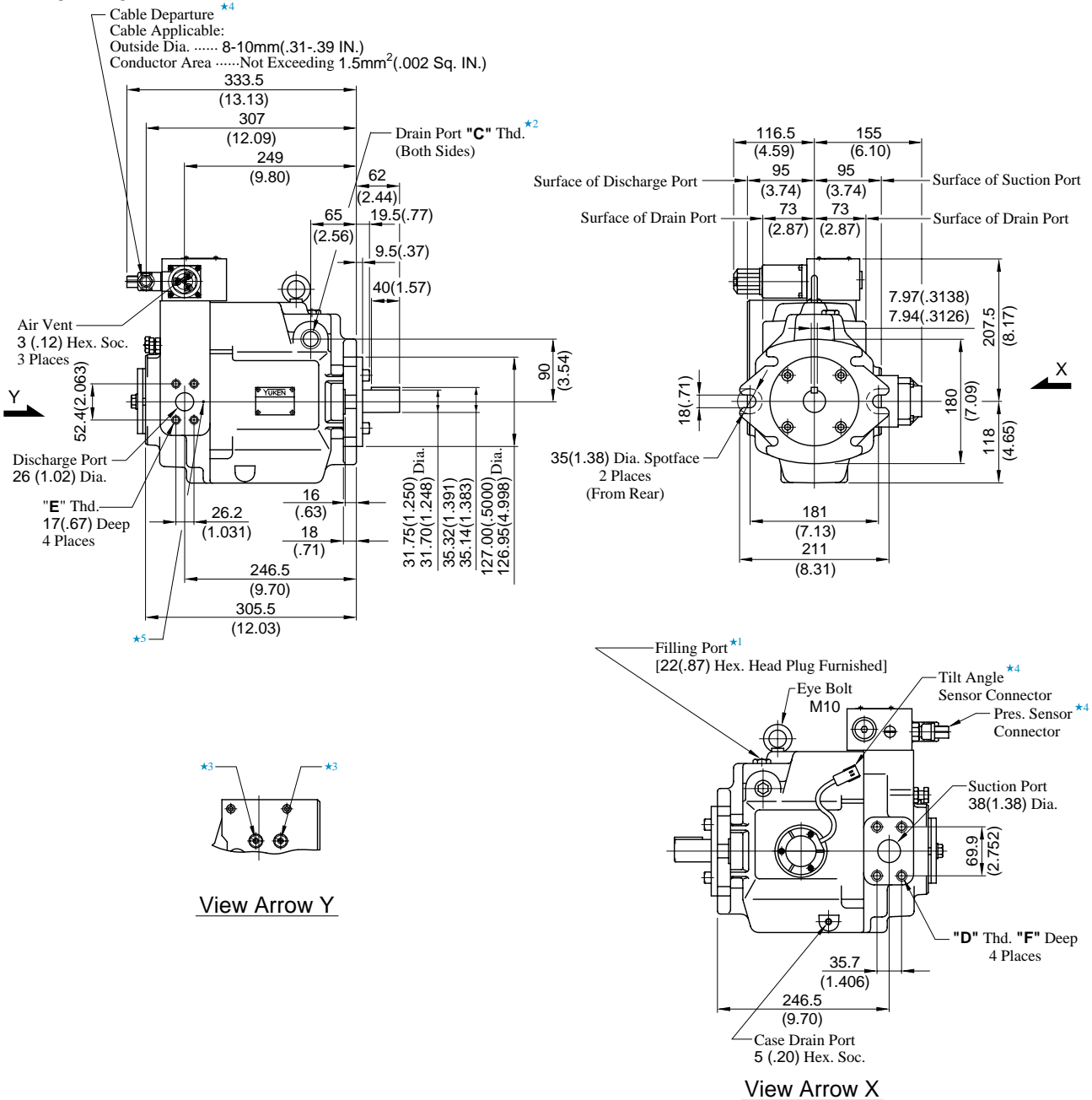

- ★ 1. Install the pump so that the "Filling Port" is at the top.
- ★ 2. Use either port of two drain ports at your option. Keep the remaining port plugged. Note that on the European design standard (6080 Design), only the left side, as viewed from the shaft end, of the drain port is machined.
- ★ 3. Do not touch the screw because it is adjusted at the time of shipment.
- ★ 4. For cable connection with amplifiers, see page 56.
- ★ 5. If you do not use the special sequence valve, plug the port (FP-SC-1/32)

Model Numbers	"C" Thd.	"D" Thd.	"E" Thd.	Dimensions mm (IN.)
				F
A70-FR04E**-60-60	Rc 3/4	M12	M10	19 (.75)
A70-FR04E**-60-6080	3/4 BSP.F			
A70-FR04E**-60-6090	3/4 NPT	1/2-13 UNC	3/8-16 UNC	21 (.83)

DIMENSIONS IN
MILLIMETRES (INCHES)

● Foot Mounting Type

Mounting bracket is common to that of pressure compensator model.
 Refer to page 21 for the dimensions of mounting bracket.

Flange Mtg. : A90-FR04E**-60-60/6080/6090

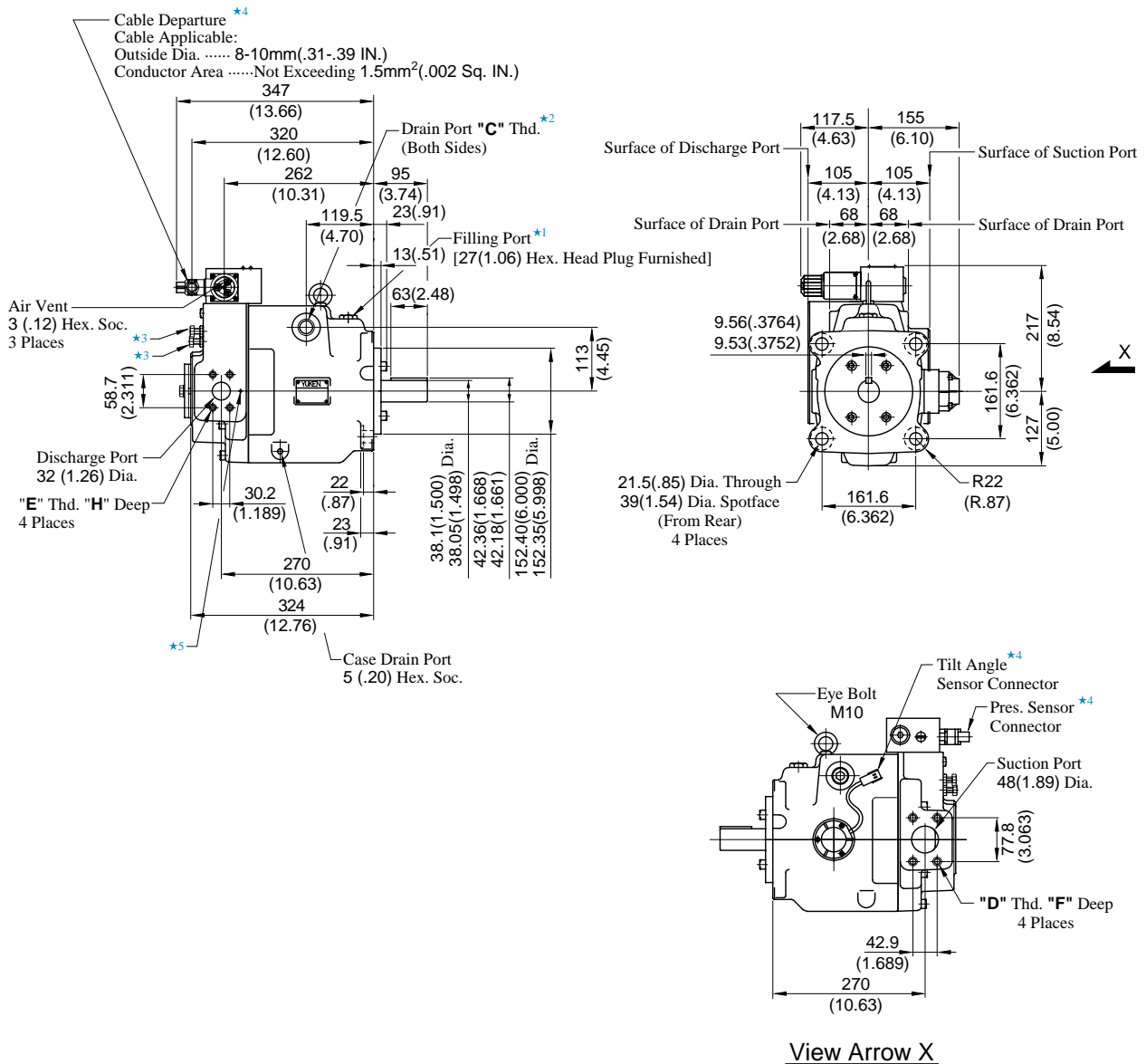

- ★ 1. Install the pump so that the "Filling Port" is at the top.
- ★ 2. Use either port of two drain ports at your option. Keep the remaining ports plugged. Note that on the European design standard (6080 Design), only the left side, as viewed from the shaft end, of the drain port is machined.
- ★ 3. Do not touch the screw because it is adjusted at the time of shipment.
- ★ 4. For cable connection with amplifiers, see page 56.
- ★ 5. If you do not use the special sequence valve, plug the port (FP-SC-1/32)

Model Numbers	"C" Thd.	"D" Thd.	"E" Thd.	Dimensions mm (IN.)	
				F	H
A90-FR04E**-60-60	Rc 3/4	M12	M10	19 (.75)	19 (.75)
A90-FR04E**-60-6080	3/4 BSP.F				
A90-FR04E**-60-6090	3/4 NPT	1/2-13 UNC	7/16-14 UNC	21 (.83)	20 (.79)

DIMENSIONS IN
MILLIMETRES (INCHES)

● Foot Mounting Type

Mounting bracket is common to that of pressure compensator model.
Refer to page 22 for the dimensions of mounting bracket.

Installation Drawing

Flange Mtg. : A145-FR04E**-60-60/6080/6090

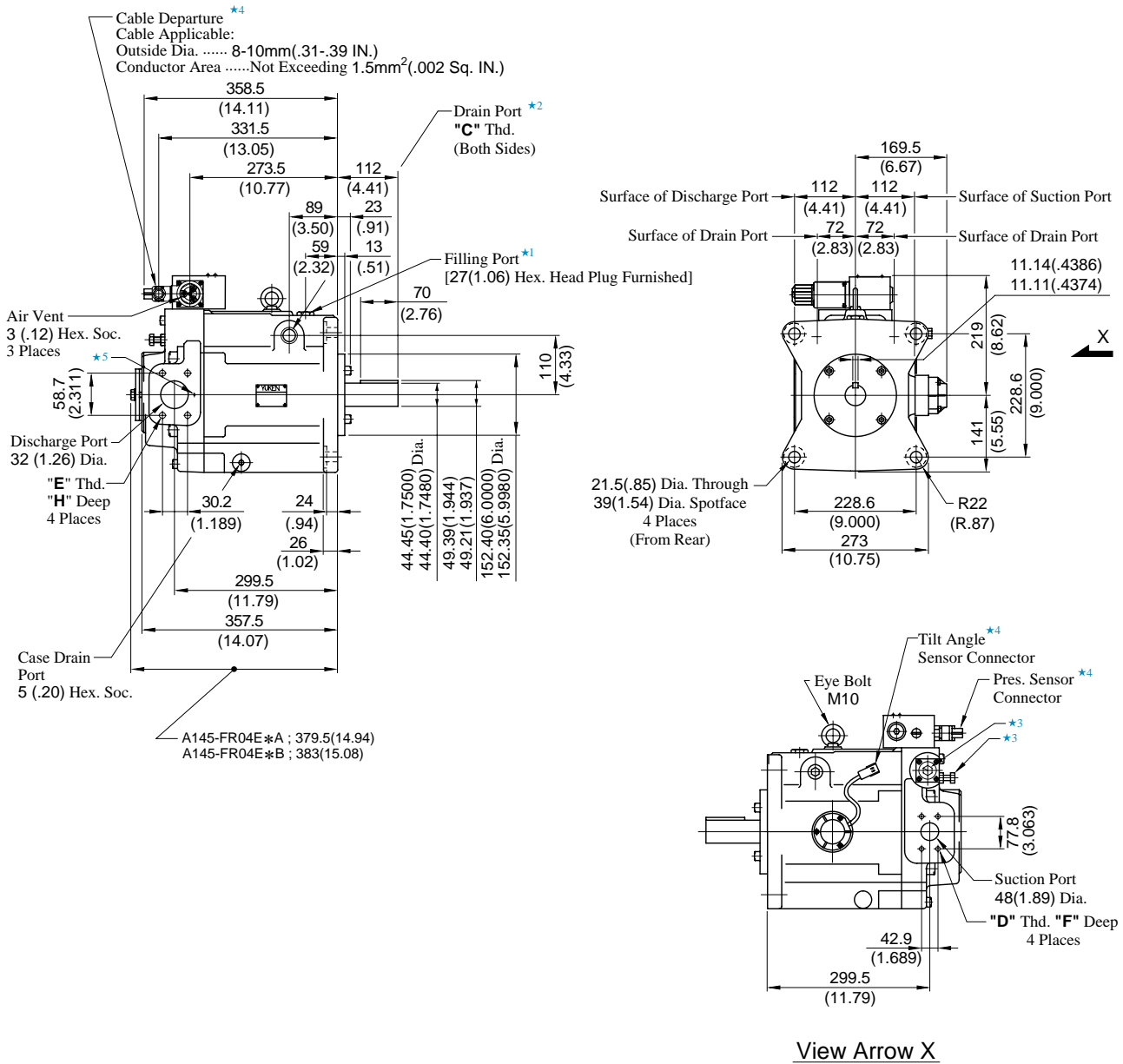

- ★ 1. Install the pump so that the "Filling Port" is at the top.
- ★ 2. Use either port of two drain ports at your option. Keep the remaining port plugged. Note that on the European design standard (6080 Design), only the left side, as viewed from the shaft end, of the drain port is machined.
- ★ 3. Do not touch the screw because it is adjusted at the time of shipment.
- ★ 4. For cable connection with amplifiers, see page 56.
- ★ 5. If you do not use the special sequence valve, plug the port (FP-SC-1/32)

Model Numbers	"C" Thd.	"D" Thd.	"E" Thd.	Dimensions mm (IN.)	
				F	H
A145-FR04E**-60-60	Rc 3/4	M12	M10	19 (.75)	19 (.75)
A145-FR04E**-60-6080	3/4 BSP.F				
A145-FR04E**-60-6090	3/4 NPT	1/2-13 UNC	7/16-14 UNC	21 (.83)	20 (.79)

DIMENSIONS IN
MILLIMETRES (INCHES)

● Foot Mounting Type

Mounting bracket is common to that of pressure compensator model.
Refer to page 23 for the dimensions of mounting bracket.

Cable connection between pump and amplifier

■ Cable connection between pump and amplifier

The cable connections between the proportional pilot valve and the sensor of the pump and the attached amplifier (SK1106) are shown below.

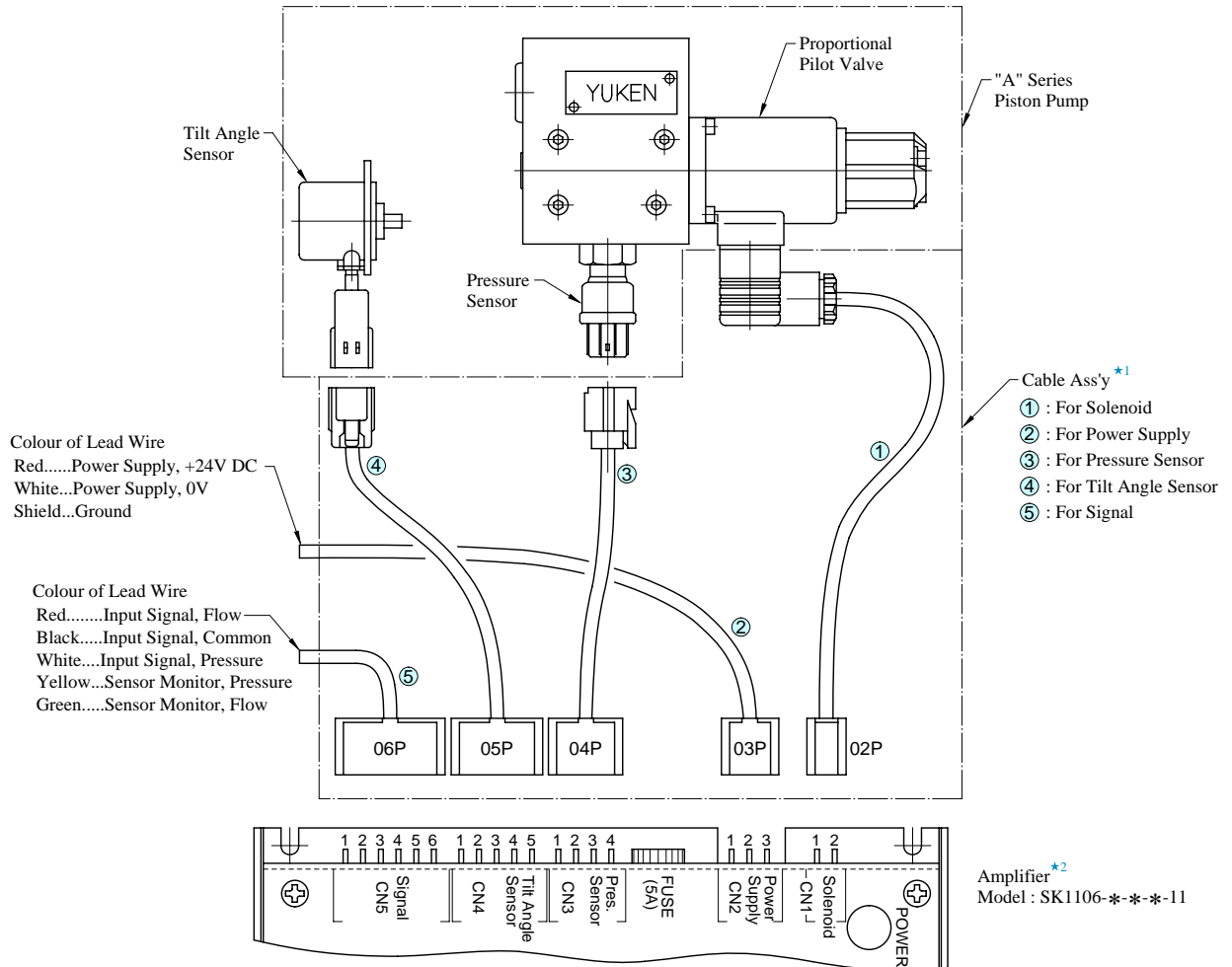

★ 1. Cable assemblies are available. When ordering, specify the cable ass'y model numbers from the table below.

Name of Cable Ass'y	Cable Ass'y Model Numbers		
	Approx. Length of Cable mm(ft.)		
	2000 (6.6)	5000 (16.4)	10000 (32.8)
① For Solenoid	SK1112-S-2-10	SK1112-S-5-10	SK1112-S-10-10
② For Power Supply	SK1112-V-2-10	SK1112-V-5-10	SK1112-V-10-10
③ For Pressure Sensor	SK1112-P-2-10	SK1112-P-5-10	SK1112-P-10-10
④ For Tilt Angle Sensor	SK1112-Q-2-10	SK1112-Q-5-10	SK1112-Q-10-10
⑤ For Signal	SK1112-C-2-10	SK1112-C-5-10	SK1112-C-10-10

★ 2. For the details of amplifier, see the following page.

Specifications / Installation Drawing

Specifications

Description	Model No.	SK1106-**-**-10
Applicable Coil Resistance		10 Ω
Input Impedance		10 kΩ
Power Supply		24 V DC (21 - 28 V Included Ripple)
Power Input (Max.)		30 W
Input Signal		Max. Flow/5V, Specified Pres./5V
Output Signal for Sensor Monitor		5V/Max. Flow, 5V/Specified Pres.
Ambient Temperature		0 - 50 °C (32 - 122 °F)
Approx. Mass		450 g (1.0 lbs.)

List of Amplifier Model No.

Pump Model Numbers	Amplifier Model Numbers
A16-★R04E★-06-42★	SK1106-★-16-06-10
A22-★R04E★-11-42★	SK1106-★-22-11-10
A37-★R04E★-01-42★	SK1106-★-37-01-10
A56-★R04E★-02-42★	SK1106-★-56-02-10
A70-★R04E★*-60-60★	SK1106-★-70-60-10
A90-★R04E★*-60-60★	SK1106-★-91-60-10
A145-★R04E★*-60-60★	SK1106-★-145-60-10

Note: Fill control pressure (at input signal is 5 V) in section marked ★.

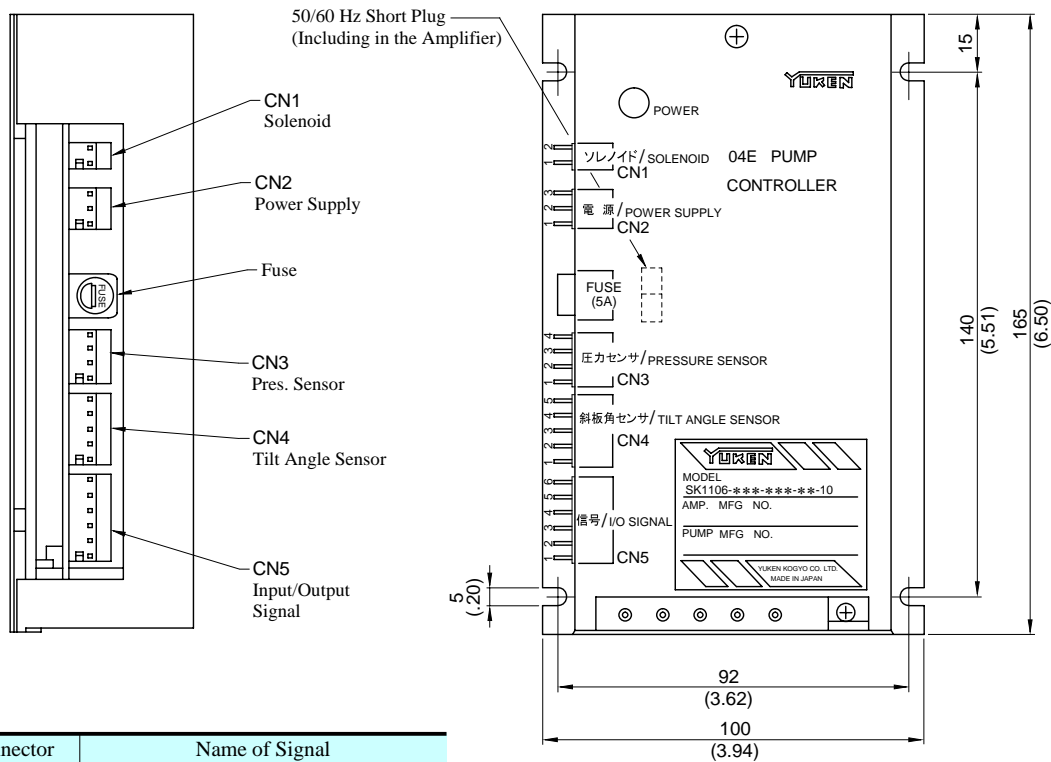

Connector	Name of Signal	
CN1 Solenoid	1	Output to pilot valve solenoid
	2	
CN2 Power Supply	1	0 [V] (0V)
	2	+24 [V] (24V)
	3	0 [V]
CN3 Pres. Sensor	1	+5 [V] Power Supply for Sensor
	2	0 [V]
	3	Input Signal - Sensor
	4	0 [V]
CN4 Tilt Angle Sensor	1	+8 [V] Power Supply for Sensor
	2	0 [V]
	3	Input Signal - Sensor
	4	0 [V]
	5	—
CN5 Input/ Output Signal	1	Input Signal - Flow (Qin)
	2	Input Signal - Common (COM)
	3	Input Signal - Pres. (Pin)
	4	Output Signal - Sensor Monitor P (SMP)
	5	Output Signal - Sensor Monitor Q (SMQ)
	6	0 [V]

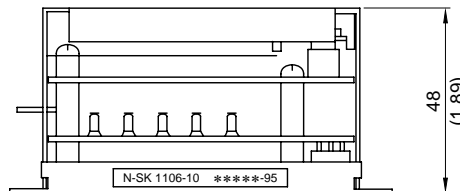

DIMENSIONS IN MILLIMETRES (INCHES)

Specifications

Graphic Symbol

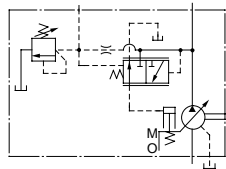

Performance Characteristics

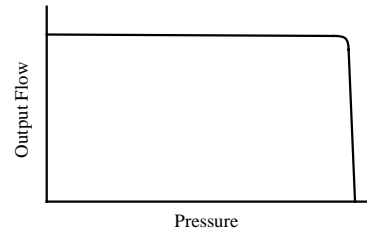

Specifications

Model Numbers	Geometric Displacement cm ³ /rev (cu. in. /rev)	Minimum Adj. Flow cm ³ /rev (cu. in. /rev)	Operating Pres. MPa (PSI)		Minimum Adj. Pres. MPa (PSI)	Shaft Speed Range r/min		Approx. Mass kg (lbs.)	
			Rated ^{*2}	Intermittent ^{*1}		Max.	Min.	Flange Mtg.	Foot Mtg.
A10-FR07-12*	10.0 (.610)	2 (.122)	16 (2320)	21 (3050)	2.0 (290)	1800	600	8.5 (18.7)	10.7 (23.6)
A16-*-R-07-*-K-32*	15.8 (.964)	4 (.244)	16 (2320)	21 (3050)	1.2 (175)	1800	600	21 (46.3)	23.2 (51.2)
A22-*-R-07-*-K-32*	22.2 (1.355)	6 (.366)	16 (2320)	16 (2320)	1.2 (175)	1800	600	21 (46.3)	23.2 (51.2)
A37-*-R-07-*-K-32*	36.9 (2.25)	10 (.610)	16 (2320)	21 (3050)	1.2 (175)	1800	600	29 (63.9)	33.3 (73.4)
A56-*-R-07-*-K-32*	56.2 (3.43)	12 (.732)	16 (2320)	21 (3050)	1.2 (175)	1800	600	36 (79.4)	40.3 (88.9)
A70-*R07S-60*	70.0 (4.27)	30 (1.83)	25 (3630)	25 (3630)	2 (290)	1800	600	60.3 (133)	72.3 (159)
A90-*R07S-60*	91.0 (5.55)	56 (3.42)	25 (3630)	25 (3630)	2 (290)	1800	600	77.5 (171)	98 (216)
A145-*R07S-60*	145 (8.85)	83 (5.06)	25 (3630)	25 (3630)	2 (290)	1800	600	94 (207)	119 (262)

- ★1. Whenever setting pressure, make sure the full cut-off pressure never exceeds the maximum intermittent pressure.
- ★2. When operating the pump exceeding the rated pressure, operating conditions are restricted.
Refer to page 6 for the details.