



**MECHANICALLY OPERATED
DIRECTIONAL VALVES**
 Rotary Type : DRT/DRG-02
 Cam Operated : DCT/DCG-01, 03
 Threaded Connection/Sub-plate Mounting

**DIRECTIONAL
CONTROLS**

General Information

Up to 25 MPa (3630 PSI), 100L/min (26.4 U.S.GPM)

These valves are chiefly used to shift the pilot circuit. Rotary Type Directional Valves and Cam Operated Type Directional Valves are available.

Rotary Type Directional Valves Page 2

These valves are used to rotate the spool either manually or by way of cam and shift the direction of oil flow. The detented mechanism incorporated in these valves prevents the valve from being changed over by itself due to vibrations or any other shocks.

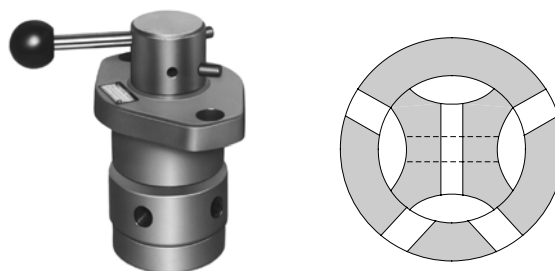

Cam Operated Directional Valves Page 6

These valves may be used to shift the direction of oil flow by depressing the spool by way of a cam.

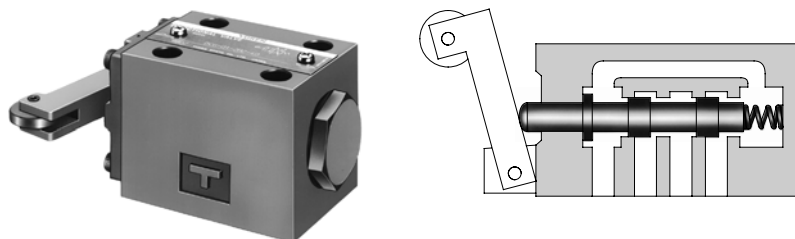

Hydraulic Fluids

Fluid Types

Any type of hydraulic fluid listed in the table below can be used.

Type of Fluids	Remarks
Petroleum Base Oils	Use fluids equivalent to ISO VG32 or VG46.
Synthetic Fluids	Use phosphate ester or polyol ester type fluid. When phosphate ester type fluid is used, prefix "F-" to the model number because the special seals (fluororubber) are required to be used.
Water Containing Fluids	Use water-glycol fluids or W/O emulsion type fluids.

Note: For use with hydraulic fluids other than those listed above, please consult your Yuken representatives in advance.

Recommended Viscosity and Oil Temperatures

Viscosity ranging between 15 to 400 mm²/s (77 to 1800 SSU)
 Oil temperatures between 15 to +70°C (5 to 160°F)
 Use hydraulic fluids which satisfy the recommended viscosity and oil temperatures given above.

Control of Contamination

Due caution must be paid to maintaining control over contamination of the hydraulic fluids which may otherwise lead to breakdowns and shorter the life of the valve. Please maintain the degree of contamination within NAS 1638-Grade 12. Use 25 μm or finer line filter.



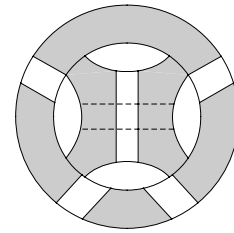

■ Specifications

Model Numbers		Rated Flow L/min (U.S.GPM)	Max. Operating Pressure MPa (PSI)	Max. T-Line Pressure MPa (PSI)	Approx. Mass kg (lbs.)	
Threaded Connection	Sub-plate Mounting				DRT Type	DRG Type
DRT-02-*D*-20*	DRG-02-*D*-20*	16 (4.2)	7 (1020)	7 (1020)*	4.7 (10.4)	3.4 (7.5)

★ When a back pressure of more than 3 MPa (435 PSI) is generated in the tank port, be sure to use External Drain Type.

■ Model Number Designation

F-	DR	G	-02	-2	D	2	-A	-R	-20	*
Special Seals	Series Connection	Type of Mounting	Valve Size	No. of Valve Position	Spool-Spring Arrangement	Spool Type	Operation Type	Drain Connection	Design Number	Design Standards
F: Special seals for phosphate ester type fluids (Omit if not required)	DR: Rotary Type Directional Valve	T: Threaded Connection	02	2	D: No-spring Detented	2	A: Reversing Dog B: Reversing Dog & Manual C: Manual	None: Intrenal Drain R: External Drain	20	None: Japanese Std. "JIS" 80: European Design Std. 90: N. American Design Std.
		G: Sub-plate Mounting	02	3		4			20	

Note: When selecting the Model type, be sure to give the model number from the following Graphic Symbols.
No combinations other than those in the table below are allowed.

■ Graphic Symbols

No. of Position	2-Position Type			3-Position Type
	Reversing Dog Operation	Reversing Dog & Manual Operation	Manual Operation	Manual Operation
Graphic Symbols				
Model No.	DR*-02-2D2-A	DR*-02-2D2-B	DR*-02-2D2-C	DR*-02-3D4-C

■ Instructions

● Changeover Torque

When the pressure of pressure port "P" and cylinder port "A" (or "B") is set to 7 MPa (1020 PSI), the valve changeover torque will be as right side table:

● 2-Way directional valves

Be sure to use the External Drain Type Valve of spool type "2" and plug the tank port.

Changeover Torque

Tank Port Back Pres. MPa (PSI)	Torque Nm (in. lbs.)
0	1.0 (8.9)
3 (435)	4.8 (42.5)

Sub-plates

Drain Connection	Japanese Standard "JIS"		European Design Standard		N.American Design Standard		Approx. Mass kg (lbs.)
	Sub-plate Model Numbers	Thread Size	Sub-plate Model Numbers	Thread Size	Sub-plate Model Numbers	Thread Size	
For Internal Drain	DRGM-02-20	Rc 1/4	DRGM-02-2080	1/4 BSP.F	DRGM-02-2090	1/4 NPT	1.9 (4.2)
	DRGM-02X-20	Rc 3/8	DRGM-02X-2080	3/8 BSP.F	DRGM-02X-2090	3/8 NPT	
For External Drain	DRGM-02-R-20	Rc 1/4	DRGM-02-R-2080	1/4 BSP.F	DRGM-02-R-2090	1/4 NPT	
	DRGM-02X-R-20	Rc 3/8	DRGM-02X-R-2080	3/8 BSP.F	DRGM-02X-R-2090	3/8 NPT	

- Sub-plates are available. Specify the sub-plate model number from the table above.
- When sub-plates are not used, the mounting surface should have a good machined finish.

Mounting Bolts

The Sub-plate Mounting Type Valves (DRG-02) only are furnished with the following mounting bolts.

Model Numbers	Socket Head Cap Screw (5 Pcs.)	
	Japanese Standard "JIS"	N. American Design Standard
	European Design Standard	
DRG-02	M8 × 45 Lg.	5/16-18 UNC × 1-3/4 Lg.

Pressure Drop

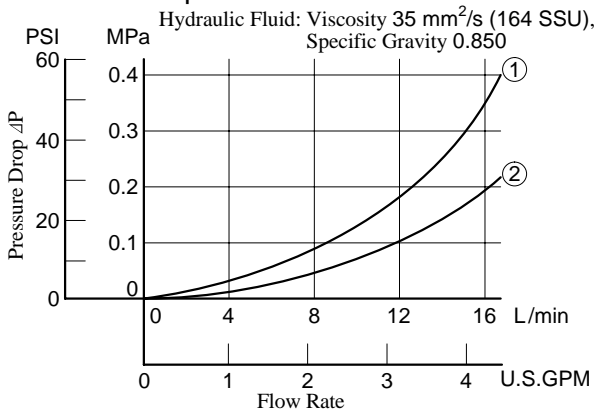

Valve Type	Pressure Drop Curve No.			
	P→A	B→T	P→B	A→T
2D2	②	②	②	②
3D4	②	②	①	②

- For any other viscosity, multiply by the factors in the table below.

Viscosity	mm ² /s	15	20	30	40	50	60	70	80	90	100
	SSU	77	98	141	186	232	278	324	371	417	464
Factor		0.81	0.87	0.96	1.03	1.09	1.14	1.19	1.23	1.27	1.30

- For any other specific gravity (G'), the pressure drop (ΔP') may be obtained from the formula below.

$$\Delta P' = \Delta P (G'/0.850)$$

DRT-02-*D*-*-20/2080/2090

● Type "A" : Reversing Dog Operation

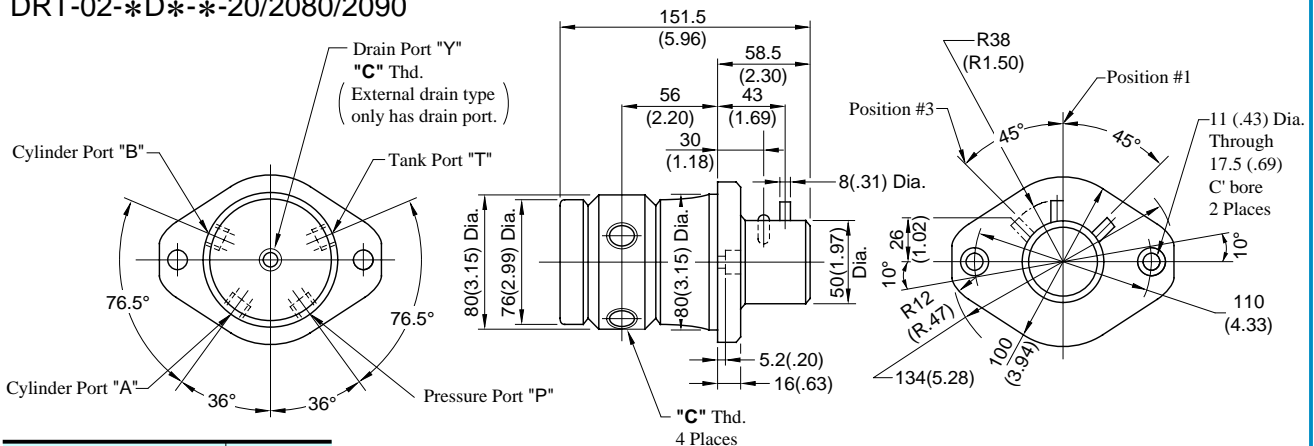

Model Numbers	"C" Thd.
DRT-02-*D*-*-20	Rc 1/4
DRT-02-*D*-*-2080	1/4 BSP.F
DRT-02-*D*-*-2090	1/4 NPT

● Type "B" : Reversing Dog and Manual Operation

● Type "C" : Manual Operation

DIMENSIONS IN MILLIMETRES (INCHES)

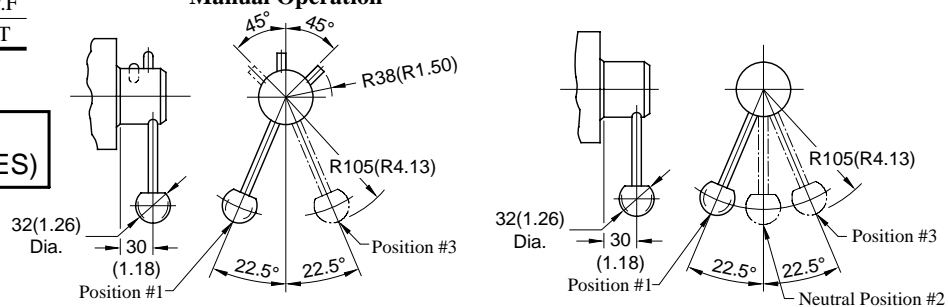

For other dimensions, refer to "Reversing Dog Operation".

DRG-02-*D*-*-20/2090

● Type "A" : Reversing Dog Operation

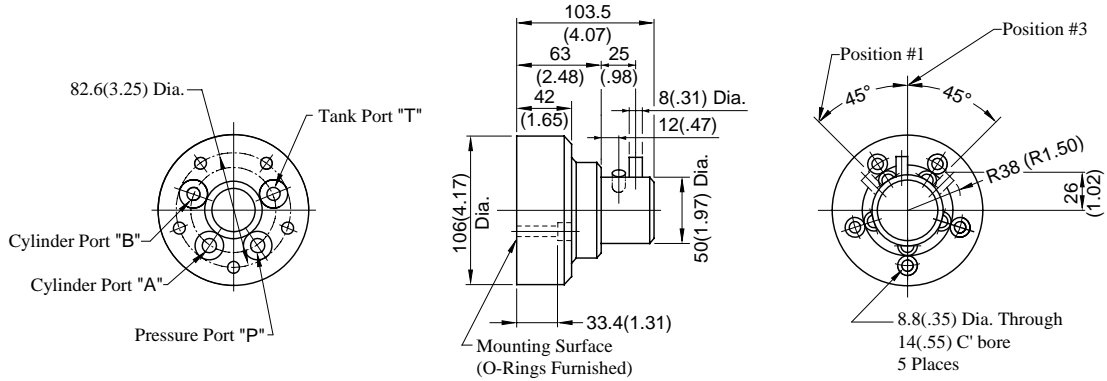

For information on Type "B": reversing Dog and Manual Operation and Type "C": Manual Operation, see DRT-02 on the previous page.

**DIMENSIONS IN
MILLIMETRES (INCHES)**

Sub-plates : DRGM-02
02X-*-*-20/2080/2090

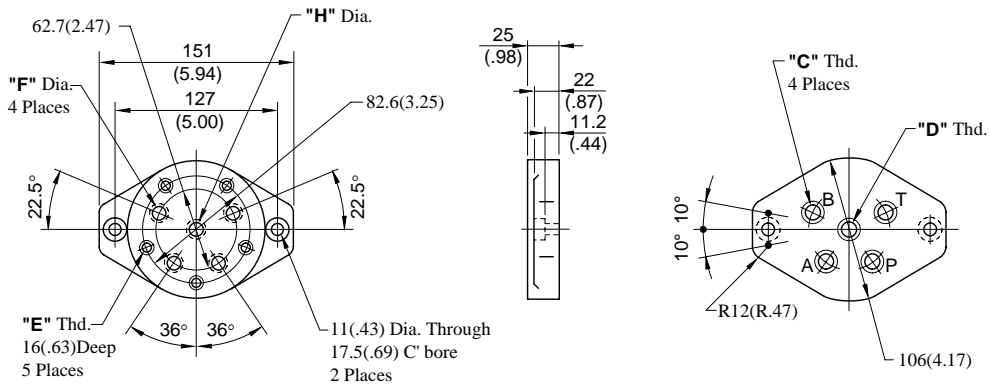

Sub-plate Model Numbers	"C" Thd.	"D" Thd.	"E" Thd.	mm (Inches)		Remarks
				F	H	
DRGM-02-20 DRGM-02X-20	Rc 1/4 Rc 3/8	—	M8	11 (.43)	—	For Internal Drain
DRGM-02-2080 DRGM-02X-2080	1/4 BSP.F 3/8 BSP.F	—	M8	11.7 (.46)		
DRGM-02-2090 DRGM-02X-2090	1/4 NPT 3/8 NPT	—	5/16-18 UNC	11 (.43)		
DRGM-02-R-20 DRGM-02X-R-20	Rc 1/4 Rc 3/8	Rc 1/4	M8	11 (.43)	11 (.43)	For External Drain
DRGM-02-R-2080 DRGM-02X-R-2080	1/4 BSP.F 3/8 BSP.F	1/4 BSP.F	M8	11.7 (.46)	11.7 (.46)	
DRGM-02-R-2090 DRGM-02X-R-2090	1/4 NPT 3/8 NPT	1/4 NPT	5/16-18 UNC	11 (.43)	11 (.43)	



CAUTION

When making replacement of seals, please do it carefully after reading through the relevant instructions in the Operator's Manual.

DRT-02-*D*-*-20/2080/2090

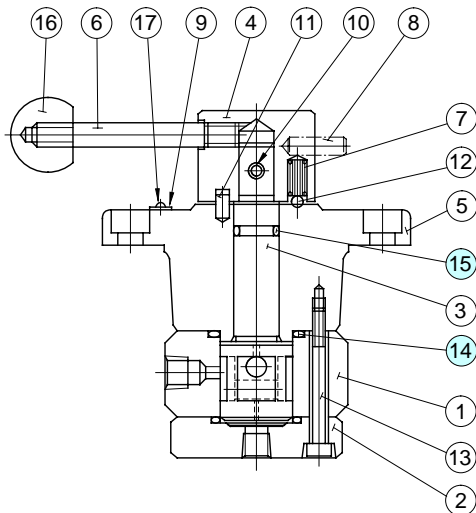

Item	Name of Parts	Part Numbers	Qty.	Remarks
14	O-Ring	SO-NB-G35	2	Included in Seal Kit
15	O-Ring	SO-NA-P16	1	(Kit No.: KS-DRT-02-20)

DRG-02-*D*-*-20/2090

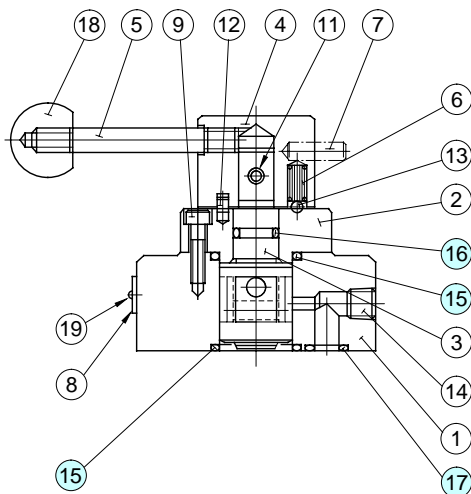

Item	Name of Parts	Part Numbers	Qty.	Remarks
15	O-Ring	SO-NB-G35	2	Included in Seal Kit (Kit No.: KS-DRG-02-20)
16	O-Ring	SO-NA-P16	1	
17	O-Ring	SO-NB-P16	4	

E

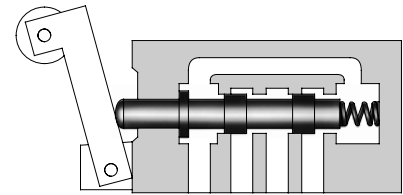

Specifications

Model Numbers		Max. Flow * L/min (U.S.GPM)	Max. Operating Pressure MPa (PSI)	Max. T-Line Pressure MPa (PSI)	Approx. Mass kg (lbs.)	
Threaded Connection	Sub-plate Mounting				DCT Type	DCG Type
DCT-01-2B*-40*	DCG-01-2B*-40*	30 (7.9)	21 (3050)	7 (1020)	1.1 (2.4)	1.1 (2.4)
DCT-03-2B*-50*	DCG-03-2B*-50*	100 (26.4)	25 (3630)	10 (1450)	4.5 (9.9)	3.8 (8.4)

* Max. flow indicates the ceiling flow which does not affect the normal function (changeover) of valves.

Model Number Designation

F-	DC	T	-01	-2	B	2	-R	-40	*
Special Seals	Series Number	Type of Connection	Valve Size	No. of Valve Position	Spool-Spring Arrangement	Spool Type	Roller Position	Design Number	Design Standards
F: Special seals for phosphate ester type fluids (Omit if not required)	DC: Cam Operated Directional Valve	T: Threaded Connection	01	2	B: Spring Offset	2 3 8	None (Normal Position) R Y (DC*-01 only) 	40	None: Japanese Standard "JIS" 80: European Design Standard 90: N. American Design Standard
			03					50	
		G: Sub-plate Mounting	01					40	None: Japanese Standard "JIS" & European Design Standard 90: N. American Design Standard
			03					50	

Sub-plates

Valve Model Numbers	Japanese Standard "JIS"		European Design Standard		N. American Design Standard		Approx. Mass kg (lbs.)
	Sub-plate Model Numbers	Thread Size	Sub-plate Model Numbers	Thread Size	Sub-plate Model Numbers	Thread Size	
DCG-01	DSGM-01-30	Rc 1/8	DSGM-01-3080	1/8 BSP.F	DSGM-01-3090	1/8 NPT	0.8 (1.8)
	DSGM-01X-30	Rc 1/4	DSGM-01X-3080	1/4 BSP.F	DSGM-01X-3090	1/4 NPT	0.8 (1.8)
	DSGM-01Y-30	Rc 3/8	—	—	DSGM-01Y-3090	3/8 NPT	0.8 (1.8)
DCG-03	DSGM-03-40	Rc 3/8	DSGM-03-2180	3/8 BSP.F	DSGM-03-2190	3/8 NPT	3.0 (6.6)
	DSGM-03X-40	Rc 1/2	DSGM-03X-2180	1/2 BSP.F	DSGM-03X-2190	1/2 NPT	3.0 (6.6)
	DSGM-03Y-40	Rc 3/4	DSGM-03Y-2180	3/4 BSP.F	DSGM-03Y-2190	3/4 NPT	4.7 (10.4)

● Sub-plates are available. Specify the sub-plate model number from the table above.
When sub-plates are not used, the mounting surface should have a good machined finish.

Mounting Bolts

Socket head cap screws in the table below are included.

Model Numbers	Socket Head Cap Screw			
	Japanese Standard "JIS" European Design Standard	N. American Design Standard	Qty.	Tightening Torque Nm (in. lbs)
DCT-01	M5 × 45 Lg.	No. 10-24 UNC × 1-3/4 Lg.	2	5-7 (43-60)
DCG-01	M5 × 45 Lg.	No. 10-24 UNC × 1-3/4 Lg.	4	5-7 (43-60)
DCG-03	M6 × 35 Lg.	1/4-20 UNC × 1-1/2 Lg.	4	12-15 (105-130)

Direction of Oil Flow for Roller Position

Model Numbers	Graphic Symbols	Roller Position and Direction of Oil Flow	
		Roller Stroke from Offset Position mm(Inches)	
		Extended(Offset)	Depressed
DCT DCG-01-2B2		P → B A → T 0 ——— 3.8 (0.150) ——— 4.6 (0.181) ——— 9.5 (0.374)	P → A B → T All ports blocked
DCT DCG-01-2B3		P → B A → T 0 ——— 3.8 (0.150) ——— 4.6 (0.181) ——— 9.5 (0.374)	All ports open
DCT DCG-01-2B8		P → B A&T ports blocked 0 ——— 3.8 (0.150) ——— 9.5 (0.374)	P → A B&T ports blocked
DCT DCG-03-2B2		P → A B → T 0 ——— 3.4 (0.134) ——— 3.8 (0.150) ——— 7 (0.276)	P → B A → T All ports blocked
DCT DCG-03-2B3		P → A B → T 0 ——— 3.0 (0.118) ——— 4.0 (0.157) ——— 7 (0.276)	All ports open
DCT DCG-03-2B8		P → A B&T ports blocked 0 ——— 3.6 (0.142) ——— 4.7 (0.185) ——— 7 (0.276)	P → B A&T ports blocked All ports blocked

Instructions

Valve Type "2B8"

Tank port "T" functions as a drain port. Directly connect it to the reservoir.
[Max. allowable back pressure 0.35 MPa (50 PSI)].

Actuation Force

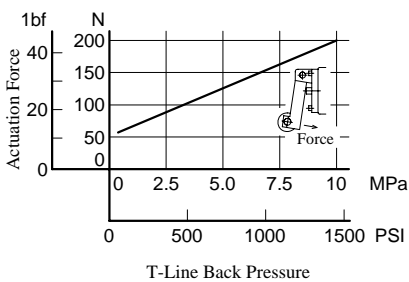

Pressure Drop

Pressure drop curves based on viscosity of 35 mm²/s (164 SSU) and specific gravity of 0.850.

DCT/DCG-01

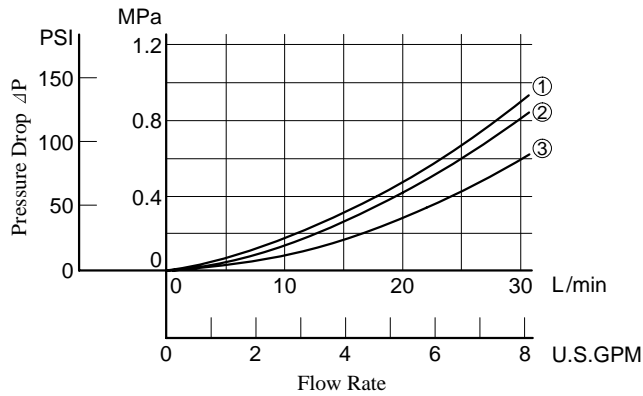

Model Numbers	Pressure Drop Curve No.			
	P→A	B→T	P→B	A→T
DCT-01-2B2	①	①	②	①
DCT-01-2B3	②	—	②	—
DCG-01-2B2	②	②	③	③
DCG-01-2B3	③	—	③	—

DCT/DCG-03

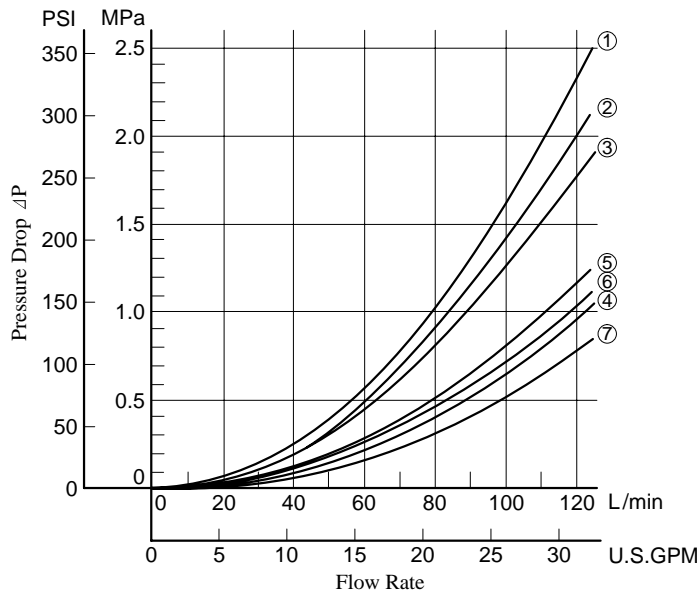

Model Numbers	Pressure Drop Curve No.			
	P→A	B→T	P→B	A→T
DCG-03-2B2	②	①	④	④
DCG-03-2B3	③	②	⑦	⑦
DCG-03-2B8	⑥	—	⑤	—

● For any other viscosity, multiply the factors in the table below.

Viscosity	mm ² /s	15	20	30	40	50	60	70	80	90	100
		SSU	77	98	141	186	232	278	324	371	417
	Factor	0.81	0.87	0.96	1.03	1.09	1.14	1.19	1.23	1.27	1.30

● For any other specific gravity (G'), the pressure drop ($\Delta P'$) may be obtained from the formula below.

$$\Delta P' = \Delta P (G'/G) \text{ where, } \Delta P \text{ is a value on the above chart and } G \text{ is } 0.850.$$

Installation Drawing

DCT-01-2B*-*-40/4080/4090

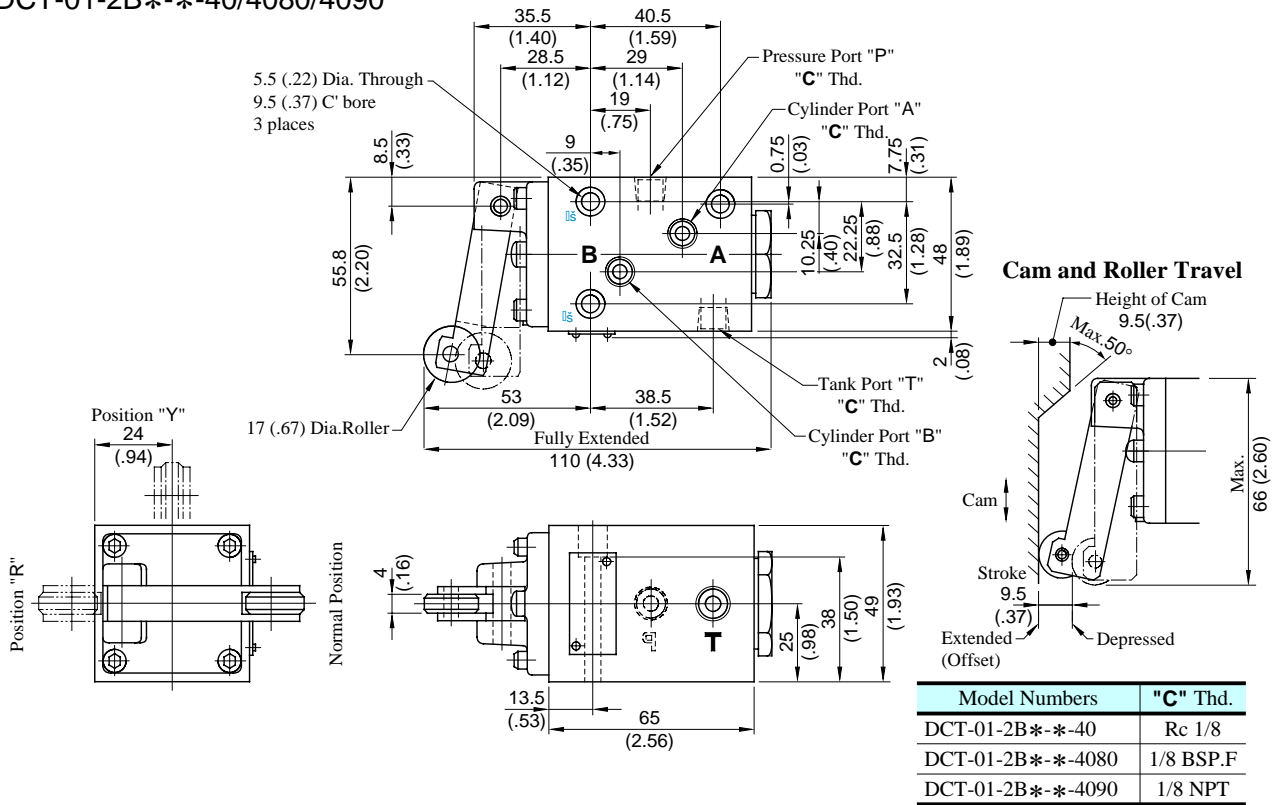

Note: When mounting the valve, be sure to use two mounting holes marked with ★.

DIMENSIONS IN MILLIMETRES (INCHES)

DCT-03-2B*-*-50/5080/5090

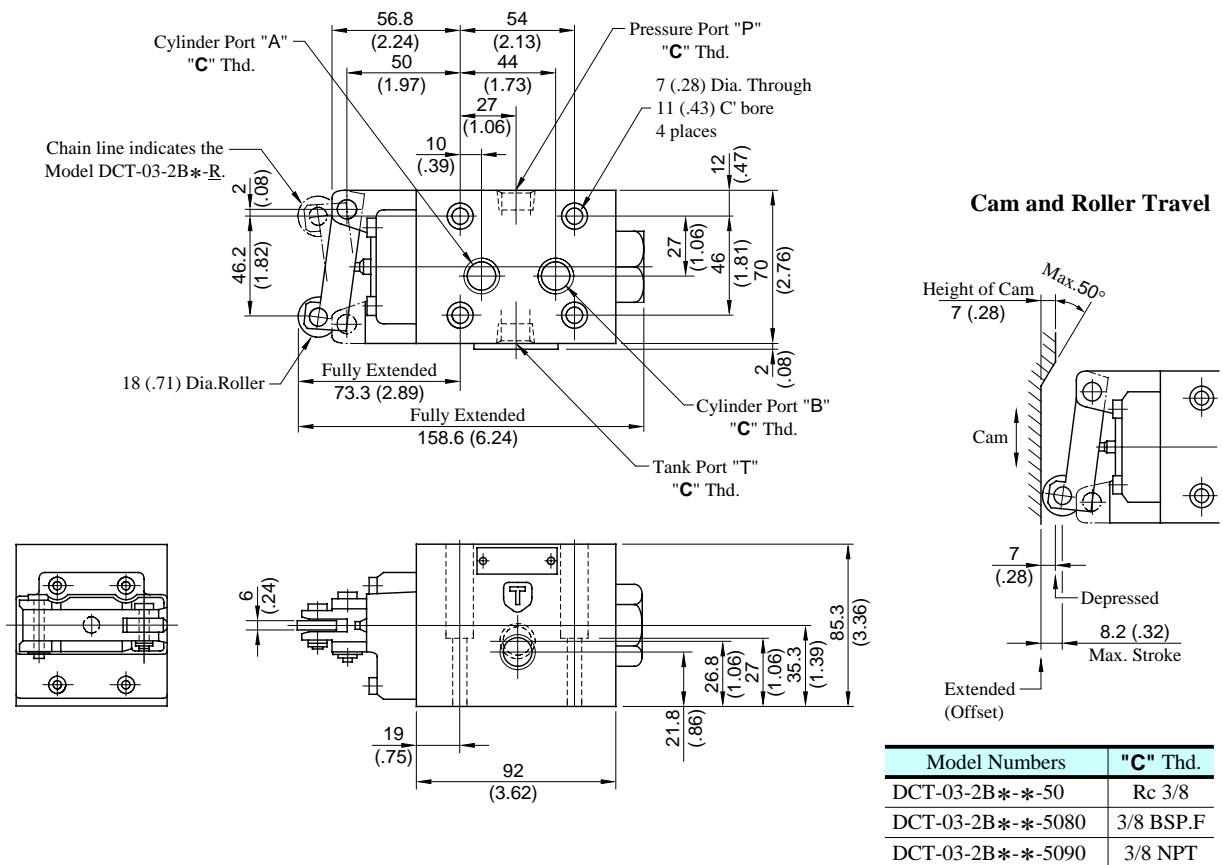

DCG-01-2B*-**-40/4090

Mounting Surface: ISO 4401-AB-03-4-A

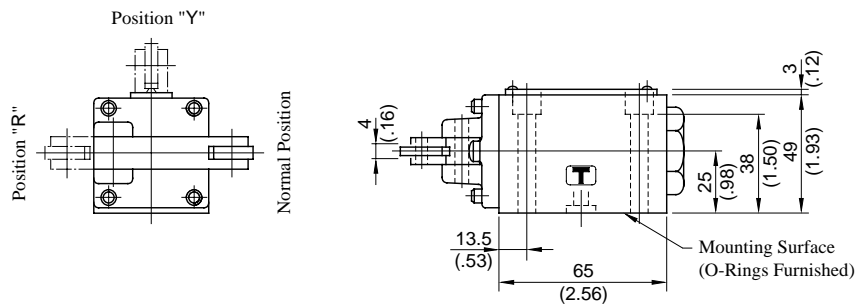
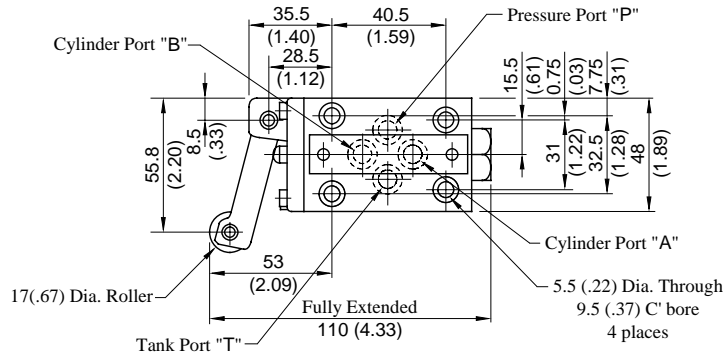

Note: For the cam and roller travel, see DCT-01 in the previous page.

DIMENSIONS IN
MILLIMETRES (INCHES)

Mounting Surface: ISO 4401-AC-05-4-A

DCG-03-2B*-**-50/5090

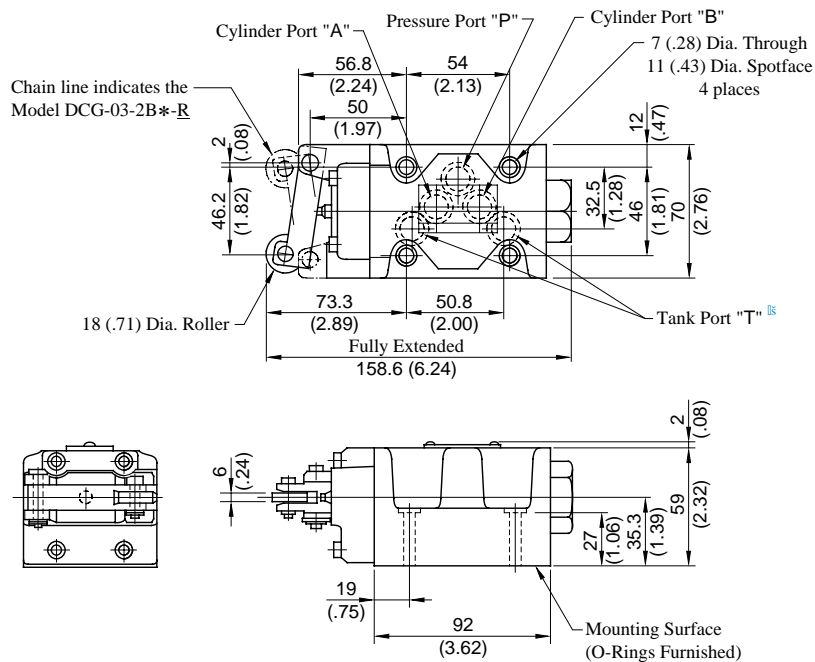

★ Although the tank port is shown on the left in our sub-plate, either may be used.
Note: For the cam and roller travel, see DCT-03 in the previous page.

Sub- plates

DSGM-01*-30/3080/3090

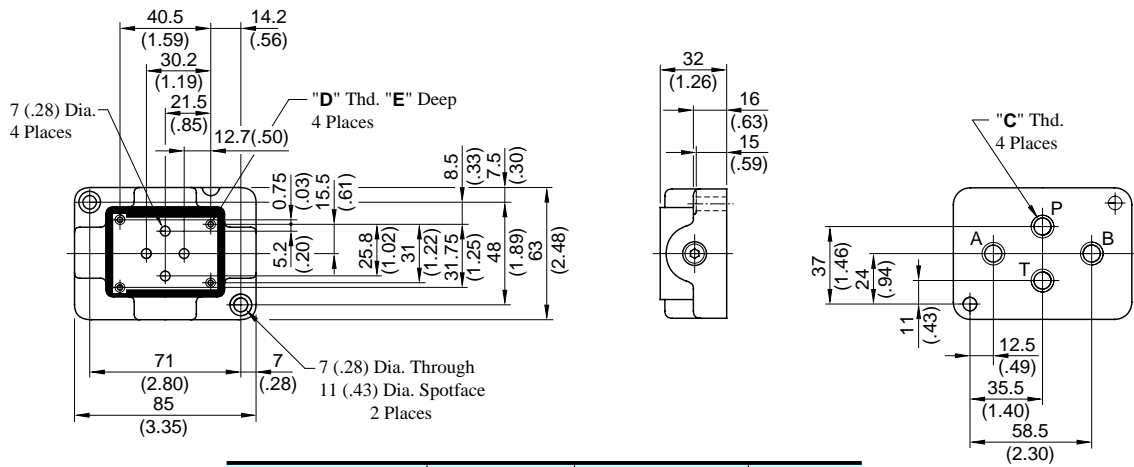

Sub-plate Model Numbers	Piping Size "C" Thd.	"D" Thd.	"E" mm (IN.)
DSGM-01-30	Rc 1/8	M5	10 (.39)
DSGM-01-3080	1/8 BSP.F		
DSGM-01-3090	1/8 NPT	No. 10-24 UNC	12 (.47)
DSGM-01X-30	Rc 1/4	M5	10 (.39)
DSGM-01X-3080	1/4 BSP.F		
DSGM-01X-3090	1/4 NPT	No. 10-24 UNC	12 (.47)
DSGM-01Y-30	Rc 3/8	M5	10 (.39)
DSGM-01Y-3090	3/8 NPT	No. 10-24 UNC	12 (.47)

DIMENSIONS IN
MILLIMETRES (INCHES)

Sub- plates

DSGM-03*-40/2180/2190

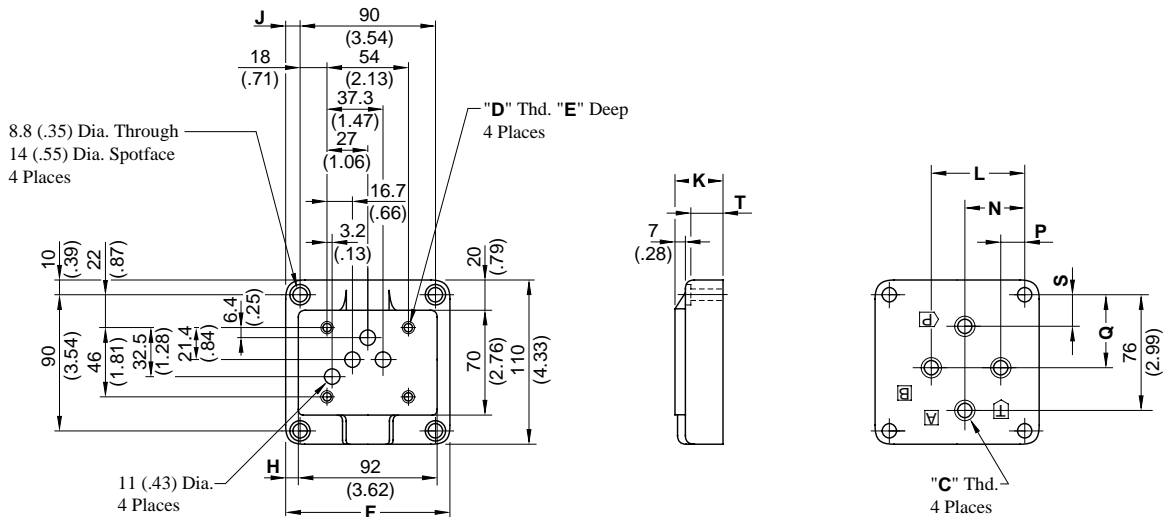

Sub-plate Model Numbers	Piping Size "C" Thd.	"D" Thd.	Dimensions mm (Inches)										
			E	F	H	J	K	L	N	P	Q	S	T
DSGM-03-40	Rc 3/8	M6	13 (.51)	110	9	10	32	62	40	16	48	21	24
DSGM-03-2180	3/8 BSP.F												
DSGM-03-2190	3/8 NPT	1/4-20 UNC	15 (.59)										
DSGM-03X-40	Rc 1/2	M6	13 (.51)	110	9	10	32	62	40	16	48	21	24
DSGM-03X-2180	1/2 BSP.F												
DSGM-03X-2190	1/2 NPT	1/4-20 UNC	15 (.59)										
DSGM-03Y-40	Rc 3/4	M6	13 (.51)	120	14	15	50	80	45	10	47	16	42
DSGM-03Y-2180	3/4 BSP.F												
DSGM-03Y-2190	3/4 NPT	1/4-20 UNC	15 (.59)										

DCT-01-2B*-*-40/4080/4090
DCG-01-2B*-*-40/4090

CAUTION

When making replacement of seals, please do it carefully after reading through the relevant instructions in the Operator's Manual.

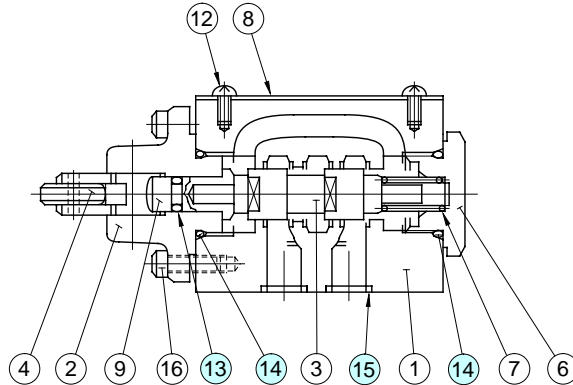

Item	Name of Parts	Part Numbers	Quantity	
			DCT-01	DCG-01
13	O-Ring	SO-NA-P5	1	1
14	O-Ring	SO-NB-P18	2	2
15	O-Ring	SO-NB-P9	0	4

Note: When ordering the o-rings, please specify the seal kit number from the table below.

DCT-03-2B*-*-50/5080/5090
DCG-03-2B*-*-50/5090

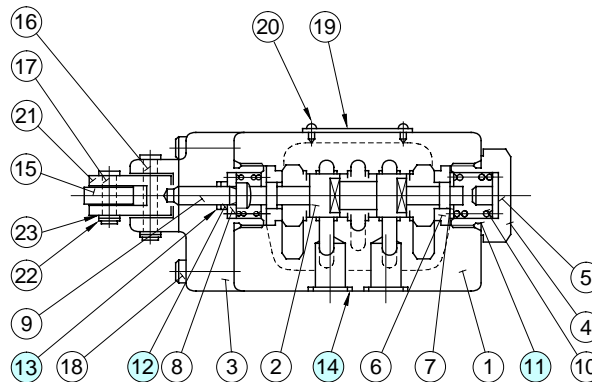

Item	Name of Parts	Part Numbers	Quantity	
			DCT-03	DCG-03
11	O-Ring	SO-NB-P21	2	2
12	O-Ring	SO-NA-P6	1	1
13	Back Up Ring	SO-BE-P6	1	1
14	O-Ring	SO-NB-A014	0	5

Note: When ordering the seals, please specify the seal kit number from the table below.

● List of Seal Kit No.

Valve Mdel Numbers	Seal Kit Numbers
DCT-01-2B*-*-40/4080/4090	KS-DCT-01-40
DCG-01-2B*-*-40/4090	KS-DCG-01-40
DCT-03-2B*-*-50/5080/5090	KS-DCT-03-50
DCG-03-2B*-*-50/5090	KS-DCG-03-50